

FITTING INSTRUCTION

Clamp mark in acc. with		Cables joining
ISO	PN	
1	L	Left directional lights
2	+	Rear fog lights
3	31	Ground
4	R	Right directional lights
5	58R	Right side parking lights
6	54	Stoplights
7	58L	Left side parking lights

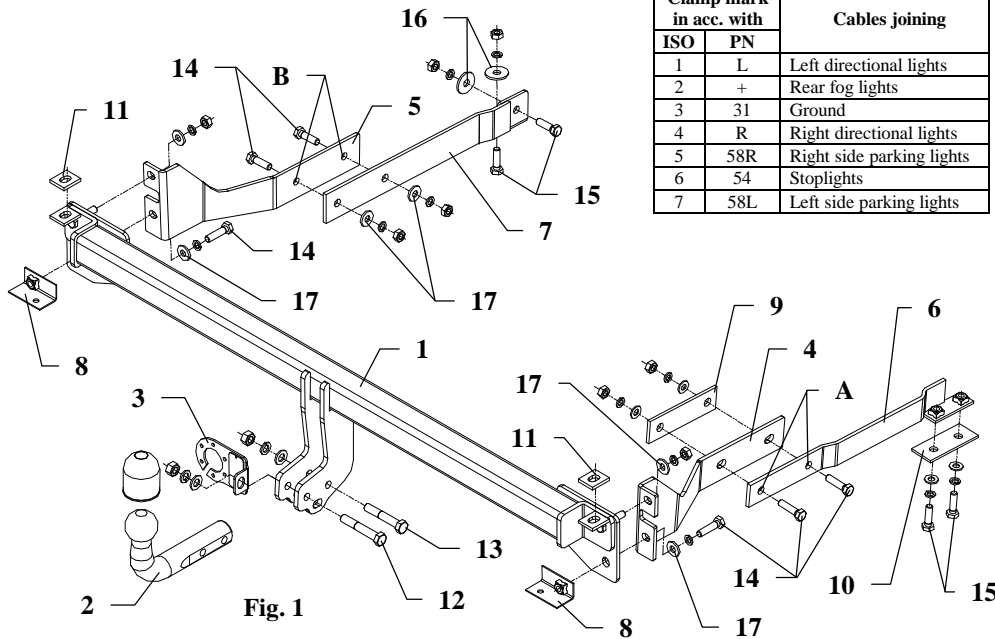

This towbar is designed to assembly in following cars:
MERCEDES 190, produced since 10.1988 till 09.1993, catalogue no. **D04** and is prepared to tow trailers max total weight **1500 kg** and max vertical load **75 kg**.

Torque settings for nuts and bolts (8,8):
M 8 - 25 Nm M 10 - 55 Nm M 12 - 85 Nm M 14 - 135 Nm

NOTE

After install the towbar you should get adequate note in registration book (at authorised service station). The car should be equipped with:

- Indicators
- Tow mirrors

After 1000km check all bolts and nuts. The ball of towbar must be always kept clear and conserve with a grease.

The instruction of the assembly

1. Disassemble a bumper together with its reinforcement.
2. From reinforcement disassemble handles (not used any more), see fig. 3.
3. In bottom part of reinforcement (in axis) saw out fragment dimension 70x45mm – in this place will be ball brackets of the towbar (see fig. 3).
4. In upper part of the reinforcement drill holes using bit $\varnothing 18,5\text{mm}$ (see fig. 3) to get dimension 1110mm. Fix angle with nut (pos. 8) see fig. 3. Use original bolts M10.

5. In the bumper cut out fragment 55x60mm (see fig. 2), for better orientation cut on internal side. Central part of cutting element will be factory marked point in the axis of the bumper.

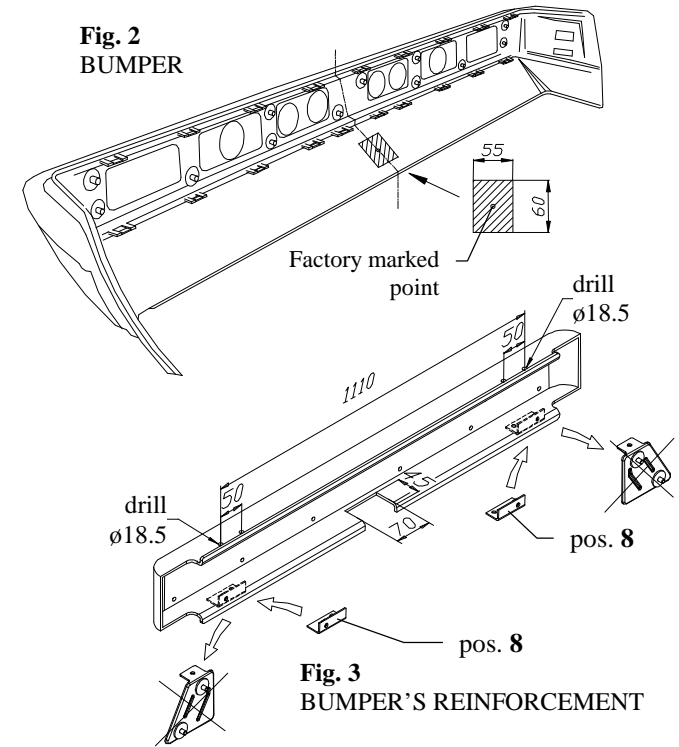

6. To the in this way prepared towbar fix main bar of the towbar (pos. 1). For that use bolts M8 after handles disassembly and nuts M8 are supplied with towbar (pos. 24). If You will feel over-stress on the reinforcement use additional elements (pos. 11) from accessories.
7. In rear wall of the car's body drill two holes using bit $\varnothing 12\text{mm}$ (find original dents with spacing 1110mm).
8. A bumper together with main bar of the towbar fix to a car:
 - protruding bolts M10 from main bar (pos. 1) put through drilled holes in rear wall of a car's body,
 - inside a trunk, on protruding bolts put brackets: pos. 5 – left side and pos. 4 – right side, then fix as shown in the figure 1.
9. Fix the bracket pos. 6: a) remove rubber plug from chassis member in point where longitudinal member touch cross member; b) put bracket pos. 6 from trunk's side in this way so holes pos. A of the bracket be at one with holes in right arm (pos. 4), fix using bolts and fish-plates pos. 9 and 10 as shown in the figure 1.
10. Fix the bracket pos. 7:
 - a) remove rubber plug from chassis member as on the right side, remove last handle of muffler fastening and thermal shield over a muffler,
 - b) through holes pos. B of the bracket pos. 5 drill holes using bit $\varnothing 11\text{mm}$,
 - c) underneath the car fix brackets pos. 5 and 7 through drilled holes using bolts M10x40mm (pos. 14),
 - d) through two rest holes in the bracket pos. 7 drill holes using bit $\varnothing 11\text{mm}$ and fix all using bolts M10x35mm (pos. 15).
11. Fix tow-ball (pos. 2) with socket plate (pos. 3) using bolts M12x75mm (pos. 12) and M12x70mm (pos. 13) from accessories. On first fix also socket plate (pos. 3). See figure.
12. Tighten all bolts according to the torque shown in the table.
13. Connect electric wires of 7-poles socket according to the instruction of the car. (Recommend to make at authorized service station).
14. Complete paint layer damaged during installation.

Towbar accessories:

Pos. 1 Main bar PCS.: 1	Pos. 6 Right arm PCS.: 1	Pos. 12 Bolt 8.8 B M12x75mm PCS.: 1	Pos. 19 Plain washer ø10mm PCS.: 4
Pos. 2 Tow ball PCS.: 1	Pos. 7 Left arm PCS.: 1	Pos. 13 Bolt 8.8 B M12x70mm PCS.: 1	Pos. 20 Spring washer ø12mm PCS.: 2
Pos. 3 Socket plate PCS.: 1	Pos. 8 Angle with nut PCS.: 2	Pos. 14 Bolt 8.8 B M10x40mm PCS.: 6	Pos. 21 Spring washer ø10mm PCS.: 12
Pos. 4 Right bracket PCS.: 1	Pos. 9 Fish-plate I 140x40x5 PCS.: 1	Pos. 15 Bolt 8.8 B M10x35mm PCS.: 4	Pos. 22 Nut 8 B M12 PCS.: 2
Pos. 5 Left bracket PCS.: 1	Pos. 10 Fish-plate II 100x40x4 PCS.: 1	Pos. 16 Washer ø35xø12x3mm PCS.: 2	Pos. 23 Nut 8 B M10 PCS.: 8
	Pos. 11 Eye 35x30x5 PCS.: 2	Pos. 17 Washer ø25xø11x3mm PCS.: 6	Pos. 24 Nut 8 B M8 PCS.: 2
		Pos. 18 Plain washer ø12mm PCS.: 2	Pos. 25 Ball cover PCS.: 1



PPUH AUTO-HAK S.J.

Produkcja Haków Holowniczych
Henryk & Zbigniew Nejman
76-200 SŁUPSK ul. Słoneczna 16K
tel/fax (059) 8-414-414; 8-414-413
E-mail: office@autohak.com.pl
www.autohak.com.pl

Towing hitch (without electrical set)

Class: **A50-X** Cat. no. **D04**

Designed for:

Manufacturer: **MERCEDES**

Model: **190**

produced since 10.1988 till 09.1993

Technical data:

D-value: 8,7 kN

maximum trailer weight: **1500 kg**

maximum vertical cup load: **75 kg**

Approval number acc. to regulations EKG/ONZ 55.01: E20-55R-01 1029

Foreword

This towbar is designed according to rules of safety traffic regulations. The towing hitch is a safety component and can be install only by qualified personnel. Any alteration or conversion of the towing hitch is prohibited and would lead to cancellation of design certification. Remove insulating compound and underseal from vehicle (if present) in the area of the matting surfaces of the towing hitch.

The vehicle manufacturer's specifications regarding trailer load and max. vertical cup load are decisive for driving whereat values for the towing hitch cannot be exceeded.

D-value formula:

$$\frac{\text{Max trailer weight [kg]} \times \text{Max vehicle weight [kg]}}{\text{Max trailer weight [kg]} + \text{Max vehicle weight [kg]}} \times \frac{9,81}{1000} = D \text{ [kN]}$$

From manufacturer

Thank you for buying our product. Their reliability has been confirmed in many tests. Reliability of towbar depends also on correct assembly and right operation. For this reasons we kindly ask to read carefully this instruction and apply to hints.

The towbar should be install in points described by a car producer.



ahkupplungen.de